

A nighttime photograph of a historic Italian town, likely Florence, featuring a stone bridge over a river. The buildings are illuminated with warm lights, and the bridge's arches and lights are reflected in the water. The sky is dark with some clouds.

Next-to-Leading Order $t\bar{t}$ + Jets Physics with HELAC-NLO

Malgorzata Worek
Wuppertal University

Outline

- General Motivation for next-to-leading order calculations
- Why do we need $pp \rightarrow t\bar{t}H \rightarrow t\bar{t}b\bar{b}$, $pp \rightarrow t\bar{t}b\bar{b}$ & $pp \rightarrow t\bar{t}j\bar{j}$ @ NLO ?
- **HELAC-NLO** framework in a nutshell
- Results for integrated and differential cross sections
- Summary & Outlook

HELAC-NLO Group:

G. Bevilacqua, INP Demokritos Athens, Greece
M. Czakon, RWTH Aachen, Germany
M.V. Garzelli, Granada University, Spain
A. van Hameren, INP Krakow, Poland
I. Malamos, Nijmegen University, Netherlands
C. G. Papadopoulos, INP Demokritos Athens, Greece
R. Pittau, Granada University, Spain
M. Worek, Wuppertal University, Germany

Contributors:

A. Kanaki
A. Cafarella
P. Draggiotis, Valencia University, Spain
G. Ossola, NY City College of Technology, USA

General Motivation for NLO

- Stabilizing the scale in the QCD input parameters \rightarrow the strong coupling constant and PDFs
- Normalization and shape of distributions first known at NLO
- Many scale processes: **V + jets, VV + jets, ttH, tt + jets, n-jets ...**
- Sometimes dynamical scales seem to work better for some observables
- How to know that the scale is chosen properly ?
- Improved description of jets

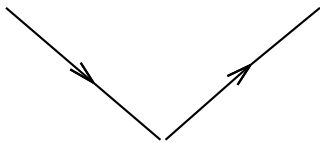

LO

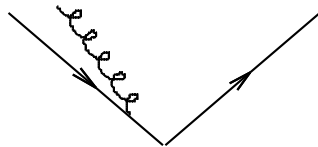

NLO

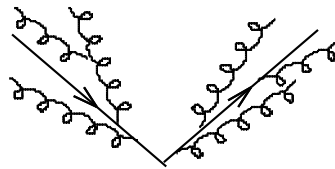

Parton Shower

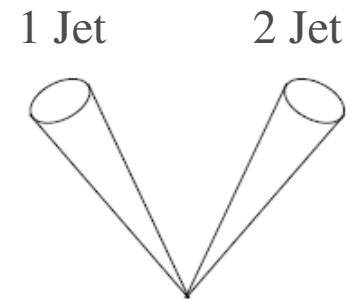

pp \rightarrow ttH \rightarrow ttbb

- **ttH**: potential discovery channel in low mass range where Higgs boson decay into **bb** pair

$$m_H \leq 135 \text{ GeV}$$

- Unique access to top & bottom Yukawa coupling
- Large QCD backgrounds: **ttjj** & **ttbb**
- **Problem 1** **combinatorial background of b-jets**: bb pair can be chosen incorrectly, lack of distinctive kinematic feature of Higgs decay jets
- **Problem 2** **b-tagging efficiency**: two b-jets for Higgs candidate can arise from mistagged QCD light jets
- **Goal**: Backgrounds need to be very well controlled

ATLAS TDR, CERN-OPEN-2008-020

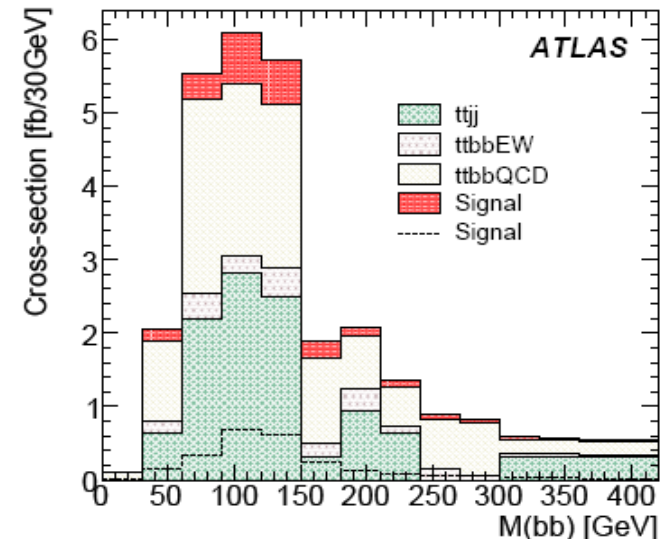

$S/B \sim 1/9$

Summary table	Significance loose/tight	Luminosity
ATLAS (Lepton+jets)	2.2	30 fb ⁻¹
CMS (Lepton+jets)	2.5/1.9	60 fb ⁻¹
CMS(Combined)	3.9/3.3	60 fb ⁻¹

Example of Feynman Diagrams

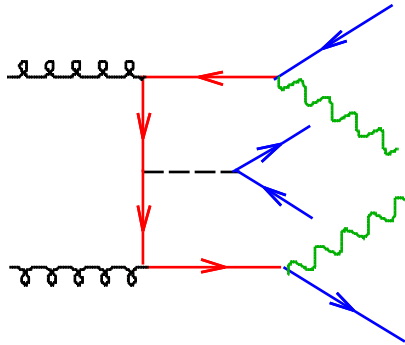

Signal process $pp \rightarrow ttH \rightarrow ttbb$

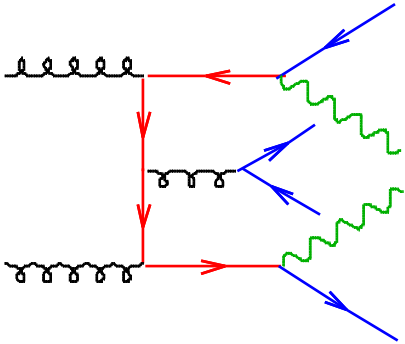

Irreducible background process $pp \rightarrow ttbb$

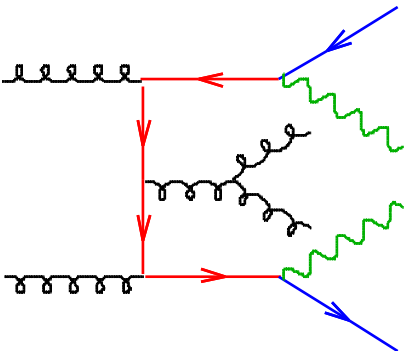

Reducible background process $pp \rightarrow ttjj$

Fat Jets in $pp \rightarrow ttH \rightarrow ttbb$

- ttH search with boosted heavy states with $p_T(j) > 200$ GeV \rightarrow no combinatorial background !

T. Plehn, G. P. Salam, M. Spannowsky '10

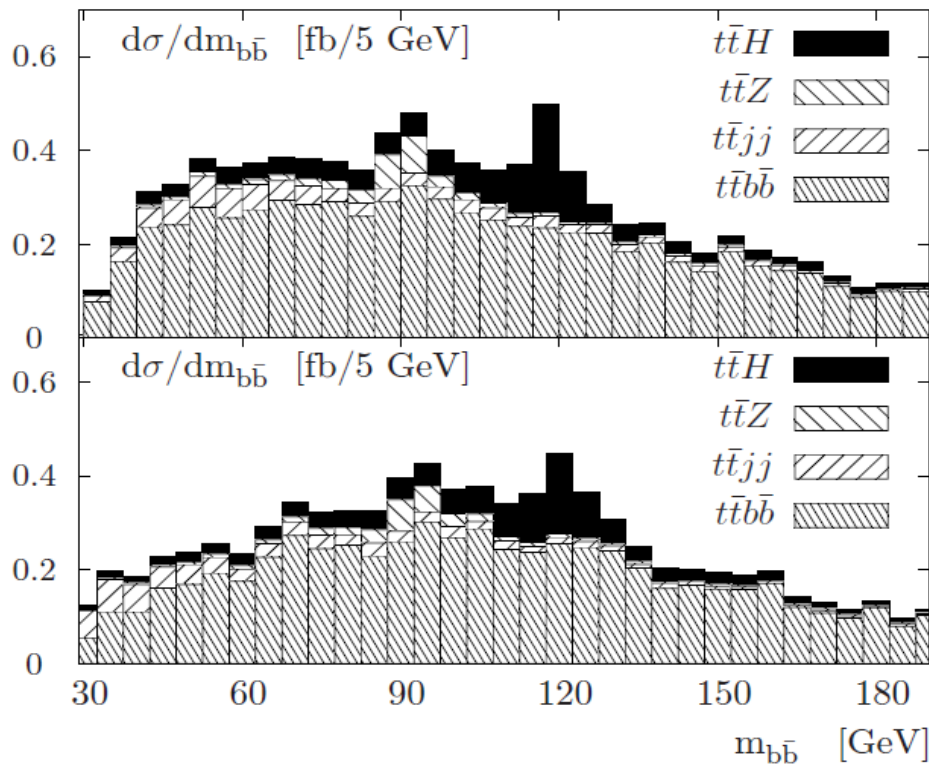

Double b tag

$\mathcal{L} = 100 \text{ fb}^{-1}$	S	B	S/B	S/\sqrt{B}
$m_H = 115 \text{ GeV}$	120	380	1/3.2	6.2
120 GeV	100	380	1/3.8	5.1
130 GeV	51	330	1/6.5	2.8

Triple b tag

$\mathcal{L} = 100 \text{ fb}^{-1}$	S	B	S/B	S/\sqrt{B}
$m_H = 115 \text{ GeV}$	57	118	1/2.1	5.2 (5.7)
120 GeV	48	115	1/2.4	4.5 (5.1)
130 GeV	29	103	1/3.6	2.9 (3.0)

- **Goal:** Determine whether NLO QCD corrections affect strongly $ttbb$ & $ttjj$ channels

Theoretical Motivation

- NLO corrections to $2 \rightarrow 4$ is current technical frontier
- Complexity of calculations triggered creation of prioritized wishlist
- **ttbb** & **ttjj** productions range among the most wanted candidates

- NLO QCD corrections to **ttH**

*W. Beenakker, S. Dittmaier, M. Krämer, B. Plümper, M. Spira, P.M. Zerwas '01
L. Reina, S. Dawson '01, S. Dawson, L.H. Orr, L. Reina, D. Wackerath '03*

- NLO QCD corrections to **ttH** \rightarrow **ttbb**

*G. Bevilacqua, M. Czakon, M.V. Garzelli, A. van Hameren, C.G. Papadopoulos,
R. Pittau, M. Worek '10 (Les Houches 2009)*

- NLO QCD corrections to **ttbb**

*A. Bredenstein, A. Denner, S. Dittmaier, S. Pozzorini '08, '09, '10
G. Bevilacqua, M. Czakon, C. G. Papadopoulos, R. Pittau, M.Worek '09*

- NLO QCD corrections to **ttjj**

G. Bevilacqua, M. Czakon, C.G. Papadopoulos, M.Worek '10

Goal: Demonstrate the power of **HELAC-NLO** system in realistic computation with 6 external legs and massive partons

NLO In A Nutshell

S. Catani, M.H. Seymour '97
 S. Catani, S. Dittmaier, M.H. Seymour, Z. Trocsanyi '02
 M. Czakon, C. G. Papadopoulos, M. Worek '09

Subtraction method for NLO calculation

$$d\sigma_{pp}^{NLO} = \sum_{ij} \int dx_1 dx_2 f_i^p(x_1, \mu) f_j^p(x_2, \mu) d\hat{\sigma}_{ij}^{NLO}(x_1, x_2, \mu)$$

$$d\hat{\sigma}^{NLO} = \int_n d\hat{\sigma}^{LO} + \int_n d\sigma^{virt.} + \int_{n+1} d\sigma^{real}$$

- Taken separately integrals are IR divergent → Only sum is finite
- Need to get individual contribution finite to perform MC integration

$$d\hat{\sigma}^{NLO} = \int_n d\hat{\sigma}^{LO} + \int_{n+1} d\sigma^{real} - \int_{n+1} d\sigma^A + \int_n d\sigma^{virt.} + \int_{n+1} d\sigma^A \Rightarrow$$

$$\int_{n+1} [d\sigma^{real} - d\sigma^D] + \int_n [d\sigma^{virt.} + d\sigma^I + d\sigma^{KP}]$$

- Local counter term added → proper approximation of $d\sigma^{real}$
- Same singular behaviour, integrated over unresolved 1-parton phase space
- Process independent method, dipole functions, I and KP operators universal !

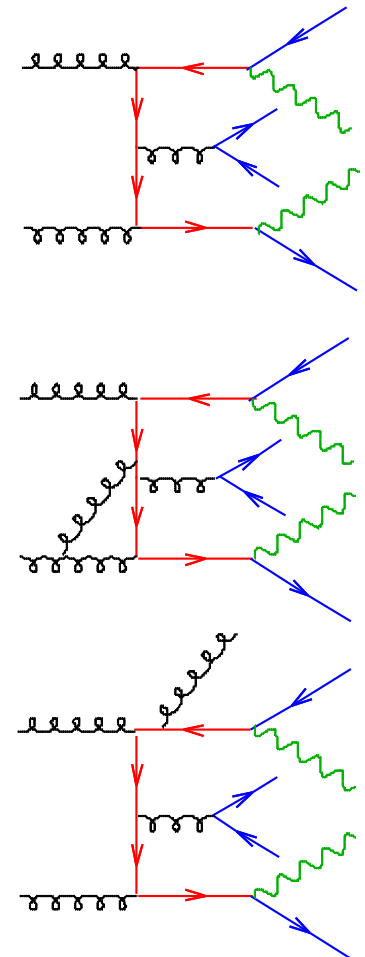

HELAC-NLO In A Nutshell



HELAC-PHEGAS

- Event generator for all parton level processes at LO
- <http://helac-phegas.web.cern.ch/helac-phegas/>

*A. Kanaki, C. G. Papadopoulos '00
C. G. Papadopoulos '01
A. Cafarella, C. G. Papadopoulos, M. Worek '07*

HELAC-1LOOP

- Evaluation of virtual one-loop amplitudes, based on **HELAC**

A. van Hameren, C. G. Papadopoulos, R. Pittau '09

CUTTOOLS

- Reduction of tensor integrals and determination of coefficients via OPP reduction method
- <http://www.ugr.es/~pittau/CutTools>

*G. Ossola, C. G. Papadopoulos, R. Pittau '07, '08
P. Draggiotis, M. V. Garzelli, C. G. Papadopoulos, R. Pittau '09*

ONELOOP

- Evaluation of scalar integrals (all divergent and finite scalar integrals are included)
- <http://annapurna.ifj.edu.pl/~hameren/>

HELAC-DIPOLES

- Catani-Seymour dipole subtraction for massless and massive cases
- Phase space integration of subtracted real radiation and integrated dipoles (**I** & **KP** operators)
- Arbitrary polarizations & phase space restriction on dipoles contribution
- <http://helac-phegas.web.cern.ch/helac-phegas/>

M. Czakon, C. G. Papadopoulos, M. Worek '09

$pp \rightarrow ttH \rightarrow ttbb$ @ LHC



$$\sqrt{s} = 14 \text{ TeV}$$

$$p_T(j) > 20 \text{ GeV}$$

$$|y(j)| < 2.5$$

$$\Delta R(j,j) > 0.8$$

$$\mu_R = \mu_F = m_{\text{top}} + m_H/2$$

$$m_H = 130 \text{ GeV}$$

CTEQ6L1, CTEQ6M

k_T algorithm $R=0.8$

pp \rightarrow ttH \rightarrow ttbb @ LHC

Scale Dependence and Integrated Cross Sections

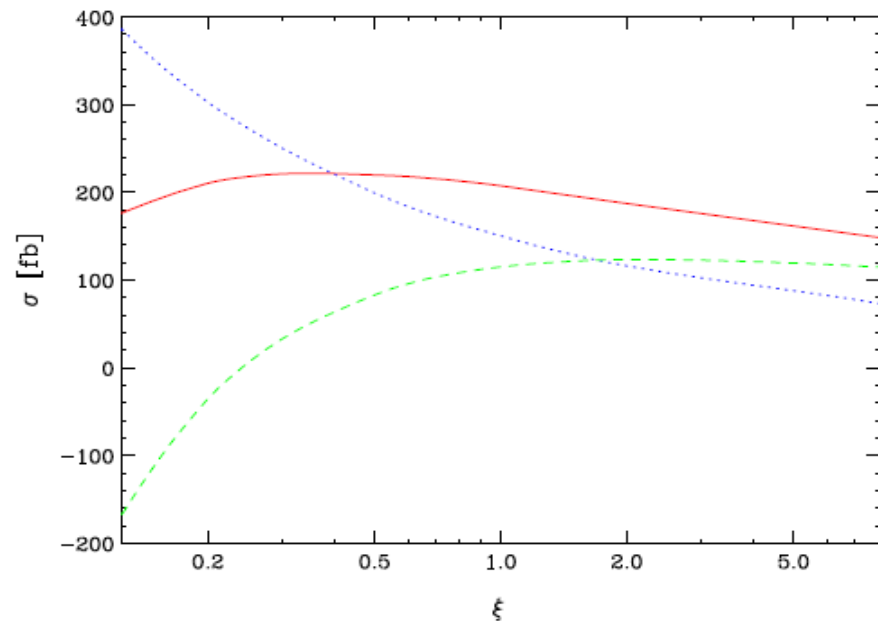

Scale dependence reduced:
33% at **LO** \rightarrow **10%** at **NLO**
28% at **NLO with jet Veto** of 50 GeV

$$\begin{aligned}\sigma_{\text{LO}}^{\text{S}} &= (150.375 \pm 0.077) \text{ fb} \\ \sigma_{\text{NLO}}^{\text{S}} &= (207.268 \pm 0.150) \text{ fb} \\ \sigma_{\text{NLO-veto}}^{\text{S}} &= (114.880 \pm 0.152) \text{ fb}\end{aligned}$$

K factor of **K = 1.38** (**K = 0.76**)
NLO QCD Corrections **38%** (**-24%**)

$pp \rightarrow ttH \rightarrow ttbb$ @ LHC

LO & NLO

● bb pair kinematics

- Transverse momentum
- Rapidity distribution

● single b & top kinematics

- Transverse momentum
- Rapidity distribution

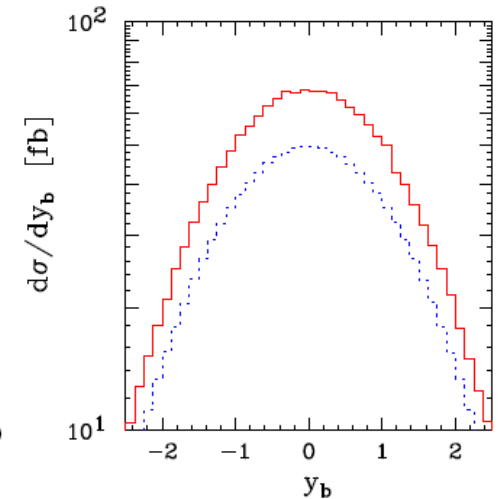
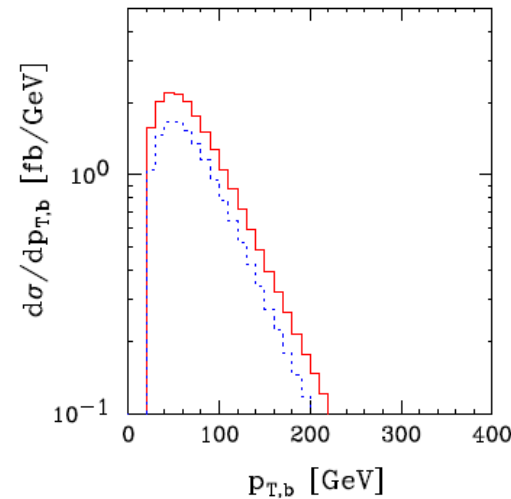
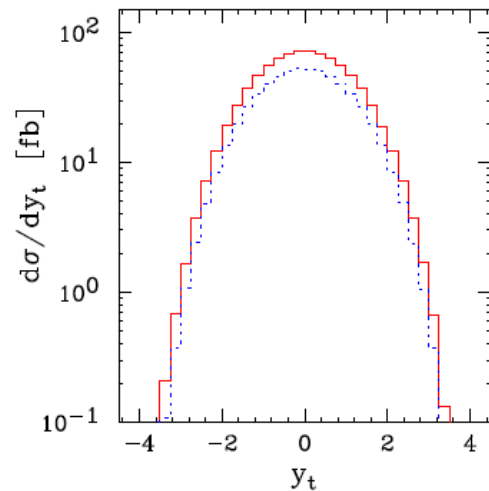
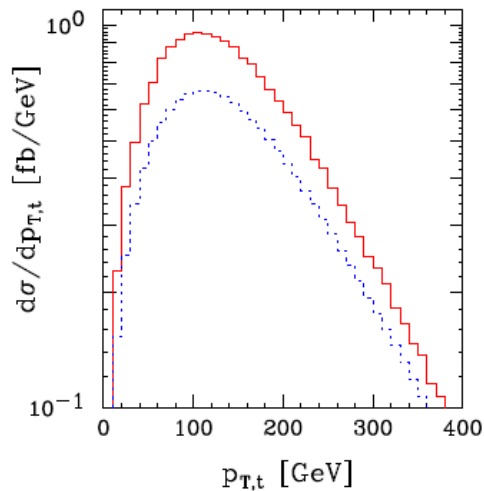
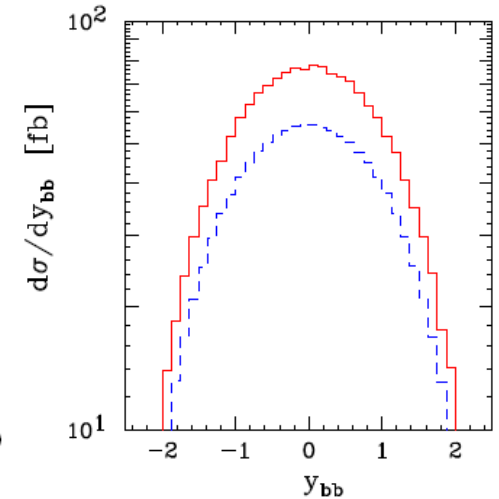
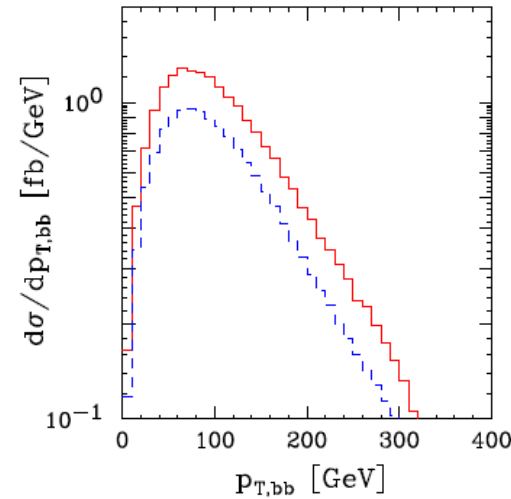

pp \rightarrow ttbb @ LHC



$$\sqrt{s} = 14 \text{ TeV}$$

$$p_T(j) > 20 \text{ GeV}$$

$$|y(j)| < 2.5$$

$$\Delta R(j,j) > 0.8$$

$$\mu_R = \mu_F = m_{\text{top}}$$

CTEQ6L1, CTEQ6M

k_T algorithm $R = 0.8$

pp → ttbb @ LHC

G. Bevilacqua, M. Czakon, C. G. Papadopoulos, R. Pittau, M. Worek '09
A. Bredenstein, A. Denner, S. Dittmaier, S. Pozzorini '08, '09

Per mille level agreement!

Process	$\sigma_{[23, 24]}^{\text{LO}}$ [fb]	σ^{LO} [fb]	$\sigma_{[23, 24]}^{\text{NLO}}$ [fb]	$\sigma_{\alpha_{\text{max}}=1}^{\text{NLO}}$ [fb]	$\sigma_{\alpha_{\text{max}}=0.01}^{\text{NLO}}$ [fb]
$q\bar{q} \rightarrow t\bar{t}b\bar{b}$	85.522(26)	85.489(46)	87.698(56)	87.545(91)	87.581(134)
$pp \rightarrow t\bar{t}b\bar{b}$	1488.8(1.2)	1489.2(0.9)	2638(6)	2642(3)	2636(3)

$m_{\text{top}} = 172.6 \text{ GeV}$

$\xi \cdot m_t$	$1/8 \cdot m_t$	$1/2 \cdot m_t$	$1 \cdot m_t$	$2 \cdot m_t$	$8 \cdot m_t$
σ^{LO} [fb]	8885(36)	2526(10)	1489.2(0.9)	923.4(3.8)	388.8(1.4)
σ^{NLO} [fb]	4213(65)	3498(11)	2636(3)	1933.0(3.8)	1044.7(1.7)

$$\sigma_{t\bar{t}b\bar{b}}^{\text{LO}} = 1489.2 \begin{array}{l} +1036.8 \text{ (70\%)} \\ - 565.8 \text{ (38\%)} \end{array} \text{ fb}$$

$$\sigma_{t\bar{t}b\bar{b}}^{\text{NLO}} = 2636 \begin{array}{l} +862 \text{ (33\%)} \\ -703 \text{ (27\%)} \end{array} \text{ fb}$$

Scale dependence reduced:

70% at **LO** → **33%** at **NLO**

K factor of **K = 1.77**

for quarks only **K = 1.03**

With jet veto of 50 GeV **K = 1.20**

pp \rightarrow ttbb @ LHC

Scale Dependence

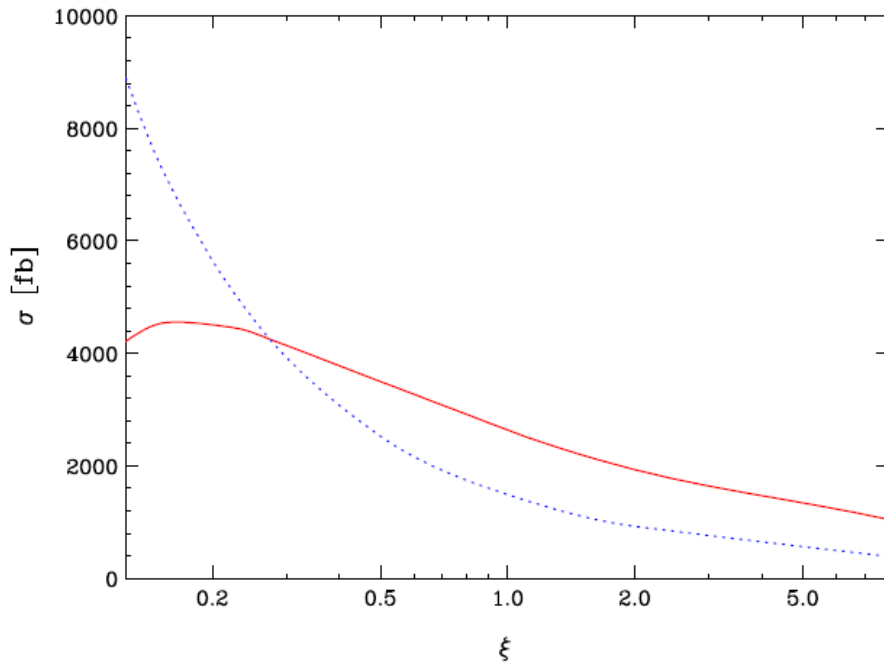

- Varying scale up or down by a factor 2 changes cross section by **70%** at **LO** and by **33%** at **NLO**

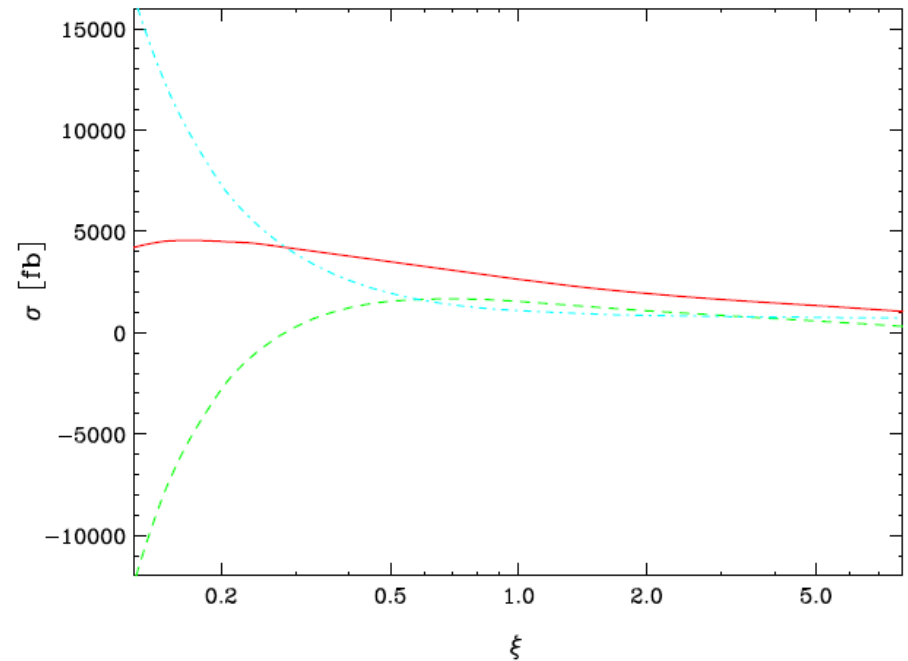

- Scale dependence at **NLO** decomposed into contribution of **Virtual Corrections** & **Real Radiation**

pp \rightarrow ttbb @ LHC



G. Bevilacqua, M. Czakon, C. G. Papadopoulos, R. Pittau, M. Worek '09

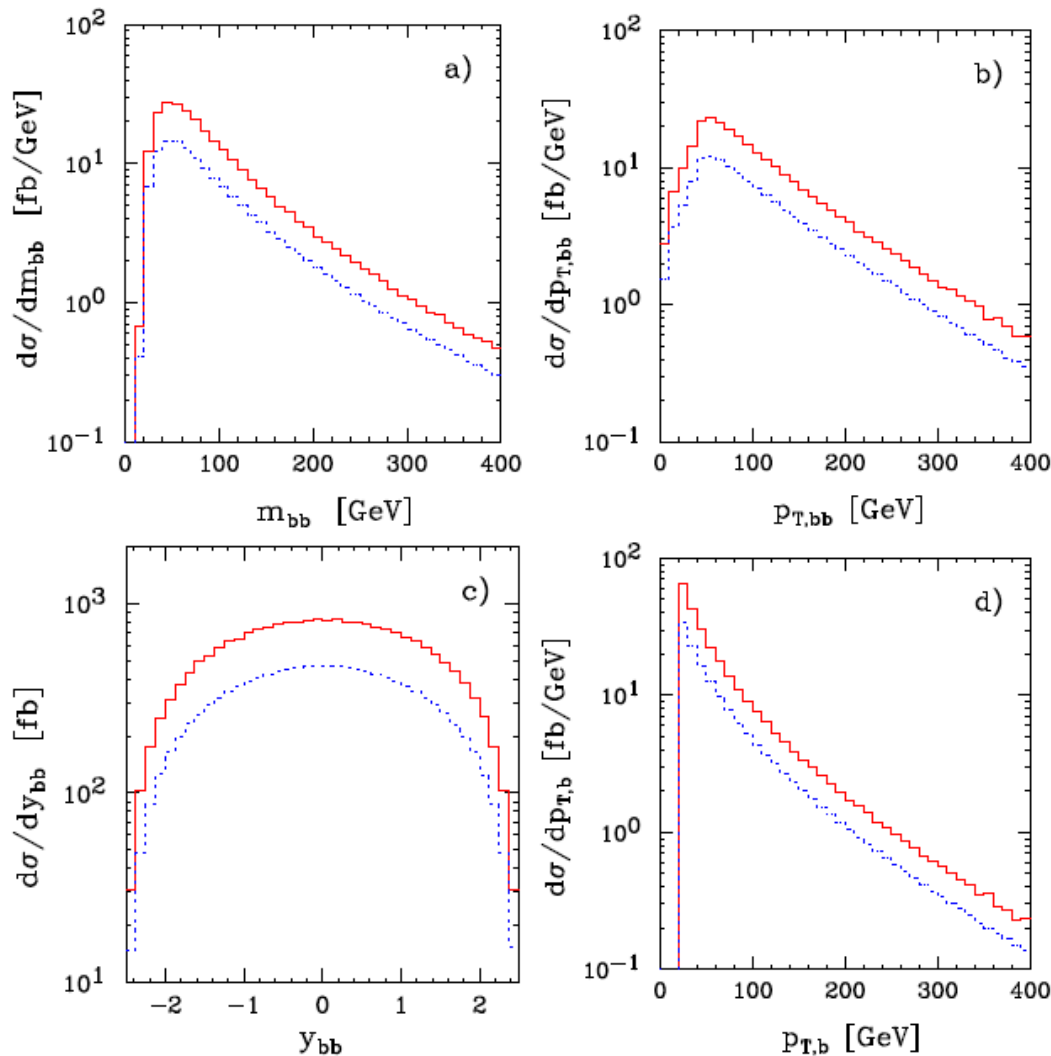

• b-jet pair kinematics

- Invariant mass distribution
- Transverse momentum
- Rapidity distribution

• single b-jet kinematics

- Transverse momentum

• LO & NLO

- Relatively small variation compared to the size but shape change important

Highly boosted b-quark pairs

A. Bredenstein, A. Denner, S. Dittmaier, S. Pozzorini '10

- LO & NLO integrated cross sections in fb
- Scale variations by factor 2
- K-factors

Setup	$m_{b\bar{b},\text{cut}}$	$p_{T,b\bar{b},\text{cut}}$	$p_{\text{jet,veto}}$	$p_{T,b,\text{cut}}$	$y_{b,\text{cut}}$	σ_{LO}	σ_{NLO}	K
I	100	-	-	20	2.5	786.3(2) ^{+78%} _{-41%}	978(3) ^{+13%} _{-21%}	1.24
II	-	200	-	20	2.5	451.8(2) ^{+79%} _{-41%}	592(4) ^{+13%} _{-22%}	1.31
III	100	-	100	20	2.5	786.1(6) ^{+78%} _{-41%}	700(3) ^{+0.4%} _{-19%}	0.89
IV	100	-	-	50	2.5	419.4(1) ^{+77%} _{-40%}	526(2) ^{+13%} _{-21%}	1.25

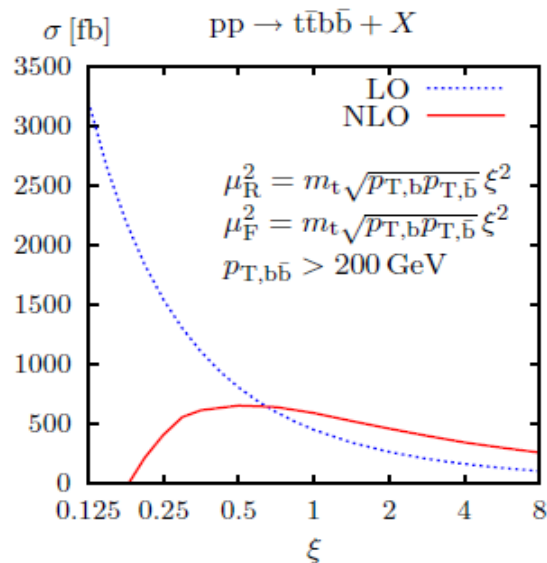

Scale dependence for dynamic scale

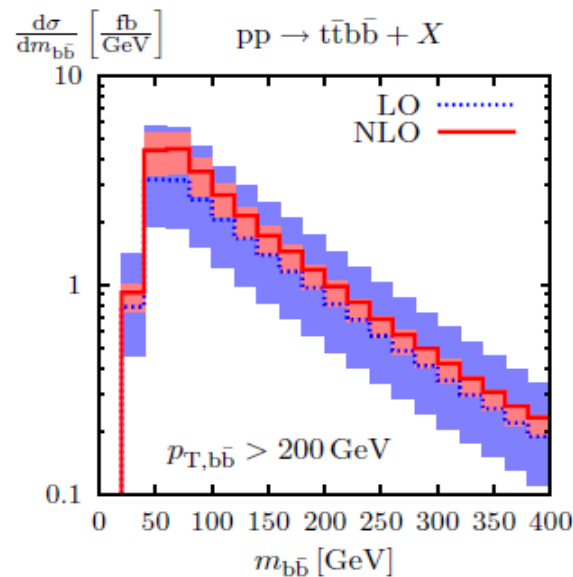

$m_{b\bar{b}}$ distribution

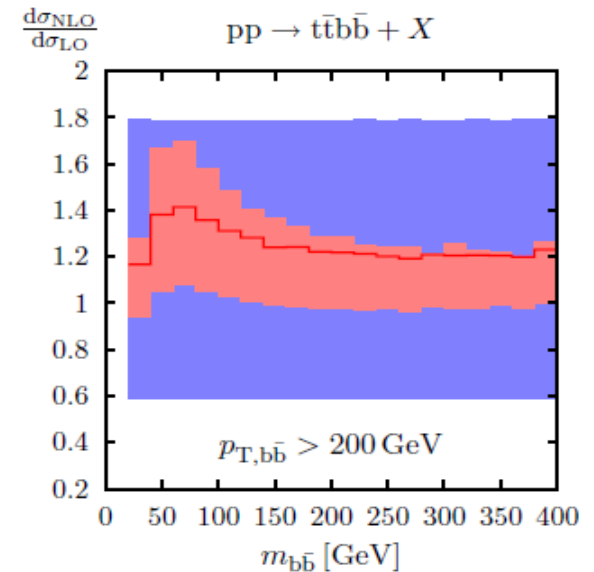

Dynamic K-factor

pp \rightarrow ttjj @ LHC



$$\sqrt{s} = 14 \text{ TeV}$$

$$p_T(j) > 50 \text{ GeV}$$

$$|y(j)| < 4.5$$

$$\Delta R(j,j) > 1.0$$

$$\mu_R = \mu_F = m_{\text{top}}$$

CTEQ6L1, CTEQ6M

k_T algorithm $R = 0.8$

pp → ttjj @ LHC

G. Bevilacqua, M. Czakon, C. G. Papadopoulos, M. Worek '10

PROCESS	σ^{LO} [pb]	CONTRIBUTION
$pp \rightarrow t\bar{t}jj$	120.17(8)	100 %
$qg \rightarrow t\bar{t}qg$	56.59(5)	47.1 %
$gg \rightarrow t\bar{t}gg$	52.70(6)	43.8 %
$qq' \rightarrow t\bar{t}qq', q\bar{q} \rightarrow t\bar{t}q'\bar{q}'$	7.475(8)	6.2 %
$gg \rightarrow t\bar{t}q\bar{q}$	1.981(3)	1.6 %
$q\bar{q} \rightarrow t\bar{t}gg$	1.429(1)	1.2 %

$$\sigma_{pp \rightarrow t\bar{t}jj+X}^{\text{NLO}} = (106.94 \pm 0.17) \text{ pb}$$

$$\sigma_{pp \rightarrow t\bar{t}jj+X}^{\text{NLO}}(p_{T,X} < 50 \text{ GeV}) = (76.58 \pm 0.17) \text{ pb}$$

K factor of **K = 0.89** (**K = 0.64**)
 → Negative shift of **11%** (**36%**)

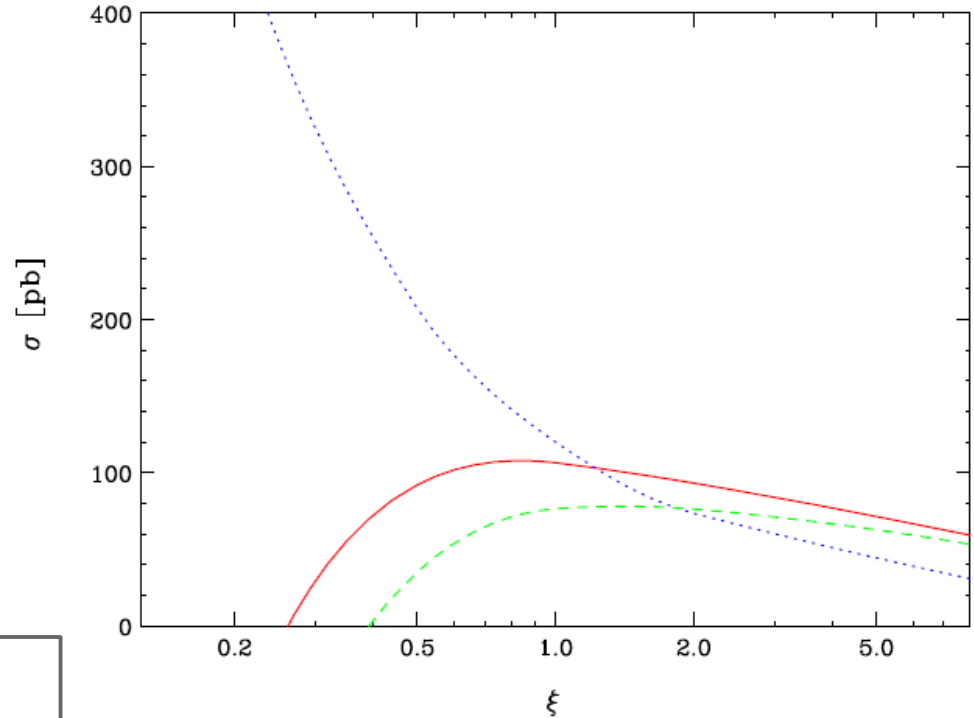

Scale dependence reduced:
72% at **LO** → **13%** at **NLO**
54% at **NLO with jet Veto** of 50 GeV

$$m_{\text{top}} = 172.6 \text{ GeV}$$

pp \rightarrow ttjj @ LHC

G. Bevilacqua, M. Czakon, C. G. Papadopoulos, M. Worek '10

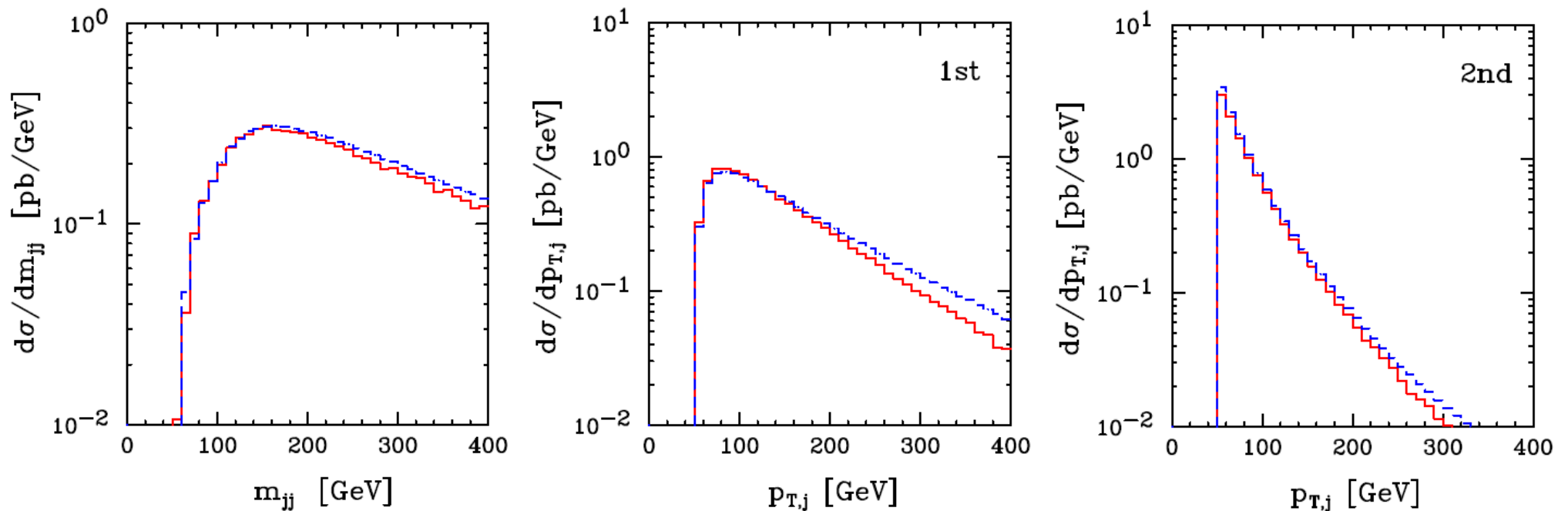

invariant mass of 2 jet system
→ size of the corrections transmitted to the distributions for low p_T
→ shapes change for high p_T

p_T of 1st hardest and 2nd hardest jet (ordered in p_T)
altered shapes up to **-39%**, **-28%** in tails
LO & **NLO**

Summary & Outlook



- Automated approach **HELAC-NLO**

→ **HELAC-PHEGAS, HELAC-1LOOP, CUTTOOLS, HELAC-DIPOLES, ONELOOP**

- First results have already been presented:

- ♣ **pp** → **ttbb** (2 independent groups)

- ♣ **pp** → **ttH** → **ttbb**

- ♣ **pp** → **ttjj**

- Reproduce results of previous study of **pp** → **ttj** $\sigma_{\text{HELAC_NLO}} = 376.6(6) \text{ pb}$ [$\sigma = 376.2(6) \text{ pb}$]

S. Dittmaier, P. Uwer, S. Weinzierl '07, '09

- More 2 → 4 processes in preparation

- Phenomenological study: fat jets @ NLO & **pp** → **ttjj** @ NLO

- Next big step – matching NLO fixed order to parton shower

- Other general & automatic systems: **BLACKHAT/SHERPA, ROCKET/MCFM, GOLEM, ...**